

**CoRsafe** in partnership with



Container Transport  
Alliance Australia

*Dedicated. Connected. Better.*

# Safe Container Loading and Transport Guide

**A GUIDE TO  
SAFETY LAWS IN  
AUSTRALIA AND  
NEW ZEALAND**

*Version published  
April, 2026*



---

# Contents

---

<b>OVERVIEW</b>	<b>3</b>
Safety Laws in Australia and New Zealand	4
Chain or Responsibility (CoR)	4
CoR Prosecutions	5
Workplace Health & Safety Laws	5
<hr/>	
<b>PROCESS</b>	<b>6</b>
Preparing a Container and its Load for Shipping	6
<hr/>	
<b>LOAD RESTRAINT</b>	<b>9</b>
Packaging of Goods	9
Distribution of the Load Within the Container	9
Types of Load Restraint	10
On Completion of Packing	13
<hr/>	
<b>TRANSPORT OF SHIPPING CONTAINERS</b>	<b>14</b>
<hr/>	
<b>RECEIPT AND UNPACKING OF CONTAINERS</b>	<b>15</b>
<hr/>	
<b>OTHER SAFETY / COMPLIANCE ACTIVITIES</b>	<b>16</b>
Pests / Contamination	16
Water Damage / Leakage	16
<hr/>	
<b>SUMMARY</b>	<b>17</b>
<hr/>	
<b>DISCLAIMER</b>	<b>17</b>
<hr/>	
<b>APPENDIX A - CONTAINER PACKING CHECKLIST</b>	<b>18</b>



# Overview

**Improper or careless packing of freight into shipping containers, or a lack of proper load restraint, may result in incidents during handling or transport, including on-road accidents or injury, as well as damage to the cargo itself, to the handling equipment, to transport infrastructure or to the environment.**

To address these risks, there are a number of laws and regulations in place in Australia and New Zealand (ANZ) relating to the safety and

compliance of container movements within a supply chain (both for domestic and imported/exported containers). Parties within these countries that are involved in organising or transporting a container can be held legally accountable for non-compliance, which can extend to packing and restraint failures originating with overseas exporters.

This document provides guidance on identifying and managing the safety risks of transporting freight in shipping containers, including the key steps in safe container transportation.

# Safety laws in Australia and New Zealand

ANZ laws to ensure the safety of container activities fall into two categories:

- Chain of Responsibility (CoR)
- Workplace Health & Safety (WH&S)

## Chain of Responsibility (CoR)

### ABOUT COR

The principle of Chain of Responsibility (CoR) exists in heavy vehicle transport safety laws across ANZ.

Through these laws, all parties in a supply chain share responsibility for their transport activities within that supply chain. The key risks identified under CoR include:



**Speed management**



**Driver fatigue (including fitness for duty and drug & alcohol use)**



**Vehicle mass**



**Vehicle dimensions**



**Loading and load restraint**



**Vehicle standards**

Parties in a supply chain sharing responsibility for these activities can include:

- The packer of a container;
- The party organising the collection or delivery of a container from or to a port or warehouse (i.e. the consignor, often the importer or exporter);
- The party loading or unloading containers onto / off of a truck in those countries;
- The party transporting a container on public roads in these countries; and
- The party opening and / or unloading the container within these countries.

Parties can be held accountable for their actions **OR** inactions. Each party holds a 'primary duty' to manage the safety of their transport activities within their supply chain and this duty cannot be contracted out to a third party.



**Maximum penalties for breaches of these laws now total:**

- For a business – up to \$3+ million;
- For individuals within businesses involved – up to \$300,000+ and 5 years jail.

Breaches of these responsibilities have resulted in serious accidents and injuries in Australia and New Zealand, and authorities in these countries have successfully prosecuted parties involved.

The fact that businesses in ANZ can be held liable for packing and restraint failures means that consignors of goods for transport by road (often the importer or exporter) must ensure that they engage with their suppliers, including overseas suppliers, to ensure that containers are packed and restrained appropriately before they hit the road. The most prominent risks in relation to containers are:



#### **Dimensions**

Ensuring that the height, width and length of a container do not exceed maximum limits;



#### **Load restraint**

Ensuring that loads within shipping containers are properly packed, loaded, balanced and restrained; and



#### **Gross Weight**

Ensuring that loads within containers do not exceed maximum legal gross weight limits and have accurate paperwork, especially Verified Gross Mass (VGM) declarations (i.e. the combined weight of the contents of the container and the container tare weight), and complying Container Weight Declarations (CWD).

## CoR prosecutions

Authorities in Australia have successfully prosecuted parties for failing to manage their container load restraint responsibilities.

### CASE 1

*An importer of composite timber products into Australia and its directors were prosecuted under CoR laws. The charges stemmed from their failure to ensure the overseas supplier that loaded composite timber in a container packed and restrained the goods so that they would meet Australia's load restraint laws upon arrival.*

*After being picked up from the wharf, a load of the timber composite product in the container shifted, causing the container to fall off onto a car, killing one occupant and badly injuring the occupant of another car behind. The company and directors were fined \$32,750 AUD in total. The family of the deceased occupant also sued the importer for injuries suffered.*

### CASE 2

*An importer of a container was prosecuted after a load within the container shifted whilst the truck transporting it turned around a corner. This caused the truck to fall on its side on a pedestrian crossing. Luckily no one was hurt, but the prosecution proceeded due to parties failing to manage their load restraint responsibilities.*



Further information on the duties of parties in the Chain of Responsibility (CoR) can be viewed on the website of the *Australian National Heavy Vehicle Regulator (NHVR)*: <https://www.nhvr.gov.au/safety-accreditation-compliance/chain-of-responsibility/the-primary-duty/parties-in-the-cor>

The *IMO / ILO / UNECE Code of Practice for Packing of Cargo Transport Units (CTU Code)*, Chapter 4, provides guidance on safety responsibilities in the supply chain specific to the shipment of cargo inside shipping containers. <https://www.imo.org/en/ourwork/safety/pages/ctu-code.aspx>

## Workplace Health & Safety Laws

**Relevant Workplace Health & Safety (WHS) Laws may also apply to operations concerned with container packing/unpacking and/or movement. Typically the primary duty to ensure the safety of activities as referred to above for CoR is represented similarly in WHS Laws. As such, WHS is often seen to 'pick up' where CoR 'drops off'.**

For example, a container that is loaded poorly and impacts vehicle stability would be covered under CoR. However, if while unloading the container, workers are exposed to risk of partial load collapse, this comes under WHS.

As a result, the safe loading and transport of containers is relevant under multiple legal frameworks.



# Process



This section addresses the three key touch points in the safe transportation of containers, with particular focus on load restraint, gross weights and dimensions.

The safe carriage of cargo in shipping containers should follow a common procedure, from planning the consignment; selecting and checking the suitability of the container; positioning the container safely for packing; safely loading and restraining the cargo; transporting the container to its port of departure; its safe carriage by sea; and finally its delivery at its destination.

The safe transport and arrival of cargo in shipping containers depends on the cooperation of all stakeholders in the transport chain, including:

- The **consignor** providing adequate packaging to protect the cargo, where appropriate;
- The **packer** checking that the container is free from signs of damage, water ingress or significant rust;
- The **packer** placing the cargo items and / or packages into (or onto) the container, ensuring that they are properly positioned and secured to withstand the expected dynamic forces during transport;
- The **shipper** correctly classifying and declaring the cargo, including the Verified Gross Mass (VGM) of the container and its contents;
- **Transport** and **logistics operators** (road, rail, container terminals and vessel operators) handling the container with care through the transport chain;
- The **consignee** on receipt **unpacking** the container safely, correctly reporting on the condition of the cargo to the shipper and **consignor**, and cleaning the container after unpacking prior to de-hire; and
- **All parties**, sharing information concerning the cargo, its manner of packing, restraint and relevant characteristics as needed.

## Preparing a container and its load for shipping

The party or parties involved in preparing a container and its load for shipping to ANZ should consider the following:

### DIMENSIONS

Ensuring the container length, width and height do not exceed maximum legal dimensions. This includes:

- Ensuring containers and their contents are 'in gauge';
- Ensuring any equipment scheduled for the transport of containers is the appropriate height for the container – e.g. a high cube container on a standard flat-deck truck would exceed the maximum height allowable;
- Ensuring any modifications to trailers (such as refrigeration units) do not cause container dimensions to exceed beyond the maximum legal limit.

### MAXIMUM GROSS WEIGHTS

- Ensuring the load weight does not exceed the permitted payload limits of the container or the maximum allowed gross mass according to the CSC Safety Approval Plate attached to the container;
- Checking the container to ensure the CSC approval plate is valid;
- Ensuring the gross weight of the container (i.e. the weight of the container itself and the load within) does not exceed maximum legal weights;
- Ensuring the vehicle scheduled to carry the container is suitable for the container mass.

### CONTAINER WEIGHT DECLARATION (CWD)

The responsible entity for a freight container must ensure that an operator or driver of a heavy vehicle does not transport the container by road without a complying Container Weight Declaration (CWD). The responsible entity must also ensure the CWD given to a heavy vehicle operator is not false or misleading.

In general, the responsible entity means the person who, in Australia, consigned the container for road transport using a heavy vehicle. For transport of containers outside of Australia, best practice still requires the communication of container weights to relevant parties.

A CWD is a written declaration of the weight of a container and its contents. It may be in either hard copy or electronic form, or a placard attached to the freight container. It may consist of one or more documents in different formats and must be able to be produced in its entirety to an authorised officer upon request.

A complying CWD must include the following information:

- The gross weight of the container including its cargo and tare weights;
- The container number;
- The name and residential address or business name and address in Australia of the responsible entity for the freight container; and
- The date of declaration.

If known, it is also good practice to indicate the container's centre of gravity (COG), particularly if the container has a high COG.

A complying CWD is required when transporting a freight container on a road/rail using a heavy vehicle. ***The requirement for a complying CWD is not dependent on whether the freight container is empty or loaded.***

It's a common error for the weight of the container to be misdeclared as only the weight of the contents of the container. But a complying CWD should have the gross mass declared – i.e. the weight of the contents inside the container, combined with the weight of the container itself.



Further information about Container Weight Declarations can be found on the National Heavy Vehicle Regulator (NHVR) website: <https://www.nhvr.gov.au/safety-accrreditation-compliance/on-road-compliance-and-enforcement/container-weight-declarations>

## VERIFIED GROSS MASS (VGM)

The consequences of misdeclaring the gross mass of a packed container can be far reaching. Should a discrepancy between the declared gross mass and the actual gross mass of a packed container go unnoticed, it could have an adverse impact on the safety of the ship, seafarers and shore-side workers, by leading to incorrect vessel stowage decisions and potentially collapsed container stacks or the loss of containers overboard.

In July 2016, amendments to the international **Safety of Life at Sea (SOLAS) Convention** entered into force, requiring that:

- The shipper (exporter) is responsible for providing the verified weight to the ship's master or their representative and to the container terminal representative sufficiently in advance to be used in the preparation of the ship stowage plan; and
- The verified gross mass is a condition for loading a packed container onto a ship.

For export containers from Australia, Commonwealth legislation (*the Navigation Act 2012, Marine Orders Part 42*) requires that a VGM be supplied before a container can be loaded onto a ship.

For import containers, the shipper (exporter) in the supplying country is responsible for providing the VGM to the container terminal and ship's master in the port of origin.

There are two approved methods of obtaining a VGM:

- Method 1 involves weighing a loaded container.
- Method 2 involves weighing the contents of a container (including the cargo and any dunnage and other load restraint mechanisms) and adding this to the tare weight of the container.

In Australia, the weighing equipment must either comply with existing requirements applicable to weighing equipment used for trade purposes under the National Measurement Act, or the equipment must be calibrated to accuracy standards approved by the Australian Maritime Safety Authority (AMSA).

Container terminals in Australia require the declared VGM of export containers, together with other vital information about the export consignment, to be communicated via a Pre-Receive Advice (PRA).

Several Australian container terminals are also check-weighing full import and export containers to verify whether container gross weights match the VGM information provided to the shipping line. Significant penalties are being applied when the container weight is proven to be at least one tonne above or below the originally declared weight.



For more information see: <https://www.amsa.gov.au/vessels-operators/cargoes-and-dangerous-goods/container-weight-verification>



# Load restraint

Load restraint ensures the load within the container is adequately restrained in accordance with ANZ legal requirements to stop any shifting of the load under extreme circumstances – e.g. rolling seas, sudden heavy vehicle braking or cornering, and low-speed collision. Load restraint also applies to securing the container to a vehicle for transport.

## Packaging of goods

The use of shipping containers does not eliminate the need for adequate interior packaging and restraint of cargo. Packaging requires careful consideration.

Cargo packaging should be sufficiently strong to accommodate stacking within a container, and to withstand the vertical and horizontal pressures sustained during transit by road, rail or ship.

All packaging – whether it is plastic wrapping, cases, drums, crates, etc. – should have adequate ability to withstand all the forces of normal transport while effectively containing the cargo.

## Distribution of the load within the container

When loading containers with cargo:

- Distribute heavy cargo over the floor area and ensure the centre of gravity of the packed container is correctly located.
- Do not build up irregular layers of packages. Irregular stacks without blocking and proper securing will result in damaged cargo.
- Do not stow heavy goods on top of light goods.
- Do not stow goods with tainting odours together with sensitive merchandise.
- Observe all handling instructions on packages, such as 'This side up'.

Container packing should aim to produce either a **tight stow** (where all cargo packages are placed tightly within the boundaries of the side and front walls of the container) or a **secured stow** (where packages do not fill the entire space and will therefore be secured within the boundaries of the container by blocking, bracing, shoring and / or lashing).

**High center of gravity cargoes** (tall, small footprint and / or light support structure) are subject to tipping and falling. Such items need support from adjacent packages or cargo items in a tight stow, or sufficient space around them to ensure direct lashings can be applied.

**Heavy cargo items such as machinery** (which may also have a high centre of gravity) and dense cargoes (e.g. steel coils, marble and granite blocks) all require the load to be distributed onto the major structural components of the container.

**Cargo on wheels or casters** (such as stillages), drums, coils and tubes should be packed in such a way that the container floor is not compromised.

**Non-pneumatic wheels, coils and tubes** (that may also be considered as heavy cargo items) should be supported on beams, which should in turn be placed onto the major structural components of the container.

Additionally, chocks of sufficient size should be placed against the **curved surface** and affixed to the supporting beams. Chocks should not be nailed to the container floor.

## Types of load restraint

Use securing (locking), blocking or lashing, or a combination of these methods, to prevent cargo from sliding or tipping in any direction.

In a tight stow, small gaps between the unit loads and similar cargo items which cannot be avoided, and which are necessary for the smooth packing and unpacking of the goods, are acceptable and need not be filled.

The sum of the void spaces in any horizontal direction should not exceed 15 centimetres. Where such a cumulative void is exceeded, the cargo items must be blocked in each gap, or moved to consolidate them into a single void, which can then be filled with appropriate dunnage or blocking.

Tight stows of small packages will need to be secured to prevent them from lifting during transport. Dunnage bags or netting may be required to ensure stow integrity.

Loose or secured stows require individual cargo items to be secured. The packer should consider lashing individual packages to prevent tipping and introduce friction and bracing to prevent sliding.

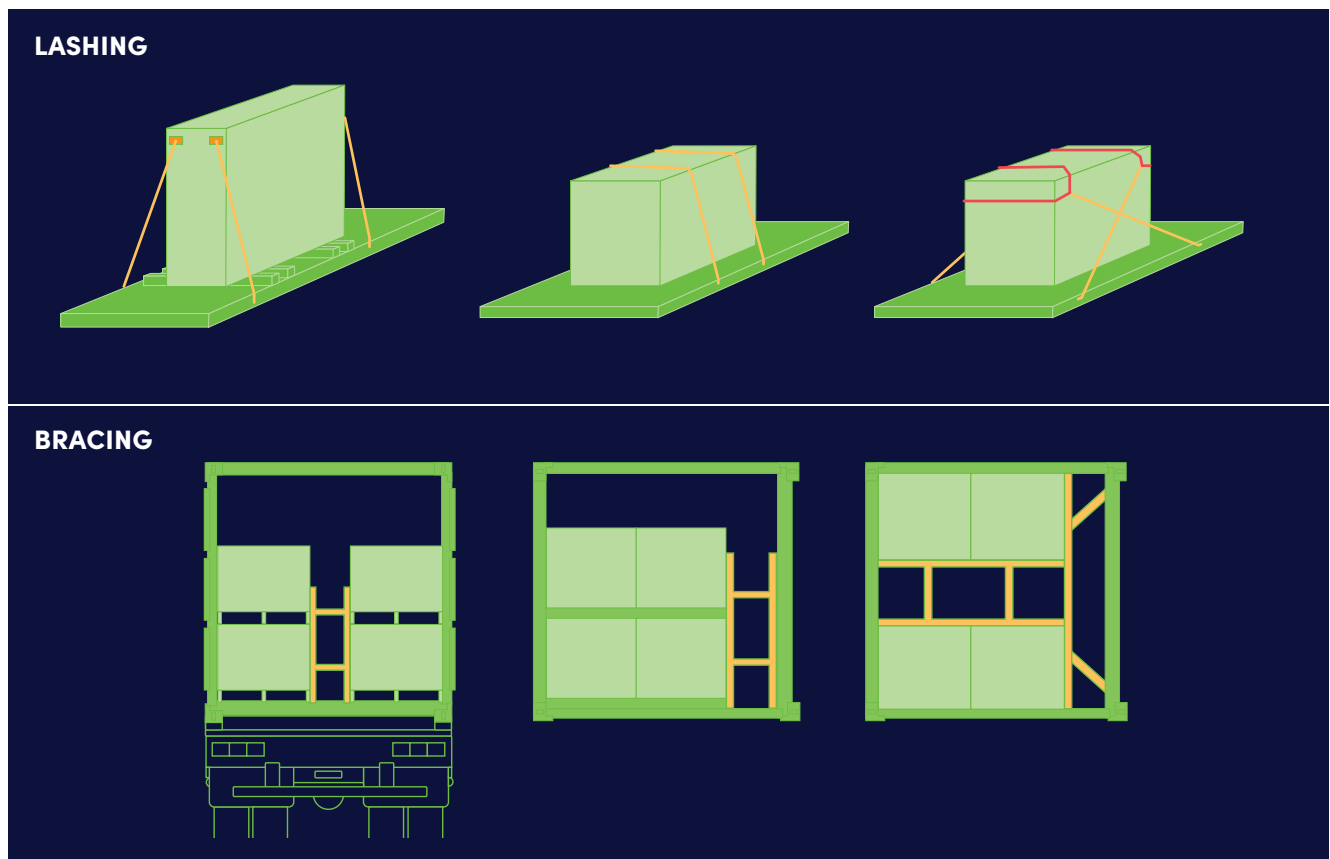

The use of the corner posts to prevent cargo from shifting fore and aft is highly recommended. If a shipment is moved by rail there should always be adequate bracing in the front and rear of the container, utilising the corner posts as restraints.

Cargo should be blocked and braced to the outer extremities of the floor to prevent lateral movement. The walls and doors of the container should not be used to support blocking and bracing.

The additional strength needed to prevent cargo from shifting and damaging the doors of the container and / or the cargo itself can be obtained by blocking and bracing against the top end rail (rear header), which connects the two rear corner posts.

When securing cargo:

- Secure the cargo in a way that ensures forces are distributed over a sufficiently large area of the container.
- Use non-slip surface friction material where appropriate to reduce sliding of packages.
- Use hooks or shackles to fasten lashings where applicable.
- Do not secure the cargo with devices overstressing the structure of the container.
- Do not overtighten the lashings, which may damage the cargo.
- Do not fasten web lashings by means of knots.
- Do not nail dunnage, blocking or bracing to the floor of containers.

Under Australian law, a load restraint system is legally required to be able to withstand forces specified in the Performance Standard contained in the [Heavy Vehicle \(Mass, Dimension and Loading\) National Regulation \(Schedule 7\)](#).



In the context of the transport of a container by road, this relates to the restraint on the heavy vehicle itself (via compliant twist locks), as well as to how the cargo inside the container is loaded and adequately restrained.

The basic safety principles that should be followed when designing a load restraint system for safe and efficient load transportation can be found in the [Australian Load Restraint Guide 2018](#).

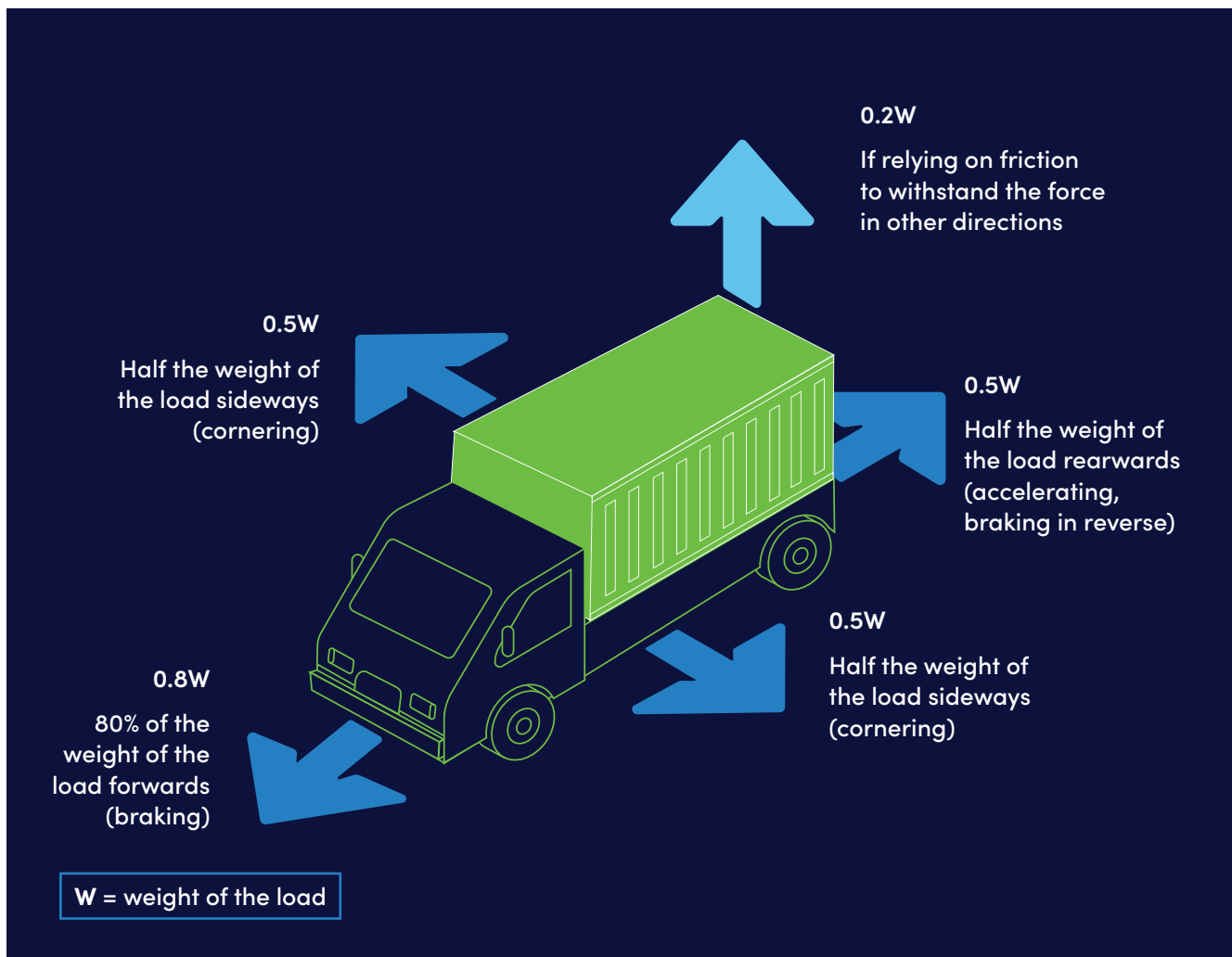
The Performance Standards specify the minimum amount of force a restraint system must be able to withstand in each direction. For heavy vehicles, these forces are:

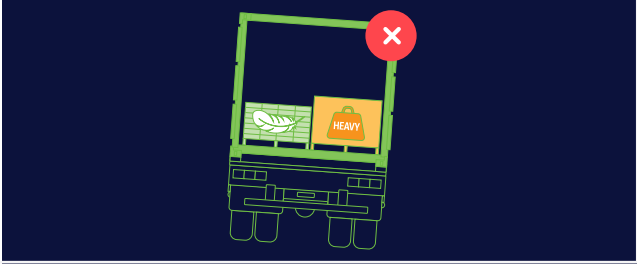
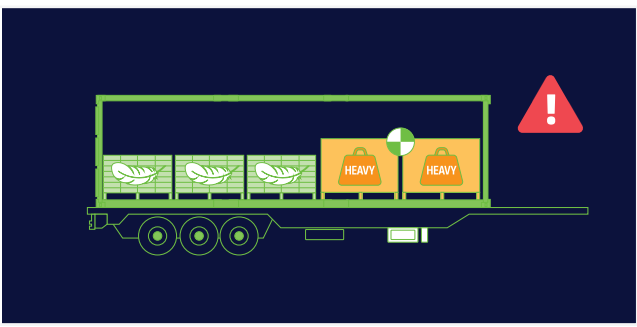
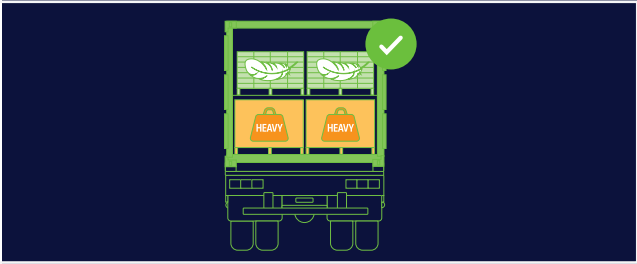

For contained loads, such as cargo inside containers, the *Australian Load Restraint Guide 2018* also advises the following.

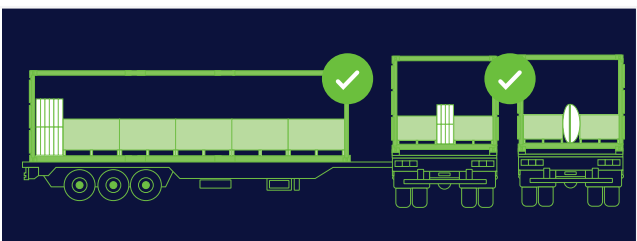
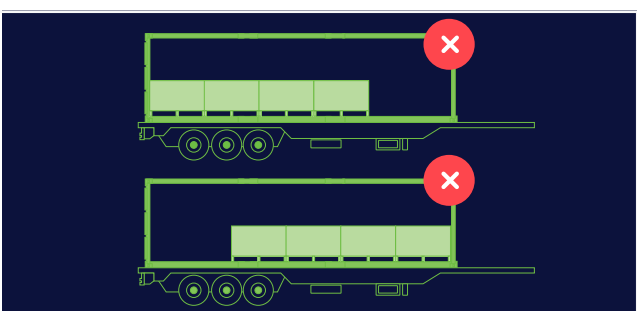
<p>Make sure there is even weight distribution both across the width and preferably along the length of the container.</p> <p>Uneven weight distribution may affect the stability of the carrying vehicle.</p>	
<p>Consignors should advise drivers how a containerised load is packed, so they can understand the impact of the load on the vehicle's stability and drive accordingly.</p> <p>Consignors should mark the centre of gravity on the container if it is more than 10% of the container length away from the container centre.</p>	
<p>Load light freight on top of heavy freight to lower the center of gravity and increase vehicle stability.</p>	
<p>Pack loads tightly within containers to prevent the load from moving sideways or horizontally.</p>	
<p>Fill gaps with empty pallets or rated dunnage, foam, custom framing or other suitable materials.</p>	
<p>Do not leave gaps unblocked in containerised loads, because freight may move during transport and impact the container walls.</p>	

---

## On completion of packing

Before closing the container, the packer should carry out these packing completion tasks. These tasks ensure the cargo can be transported safely to its destination.

- Cargoes that require fumigation at the point of origin should be treated in accordance with local legislation.
- Determine that both the interior and the exterior of the container, and its cargo, are free from visible infestation by pests.
- Dangerous goods cargo should have container placards and markings as per IMDG Code.
- Affix an ISO 17712 compliant seal when the container is being transported internationally. An accurate seal record should be maintained from point of origin to point of destination. Seal numbers should be recorded on appropriate documents. Ensure doors are properly closed and latched prior to affixing seal.
- Determine the Verified Gross Mass (VGM) of the container. Shippers are required to provide a VGM to the terminal at the port of origin and to the ship's master as a condition of loading on board a vessel.

Appendix A – Container Packing Checklist can be used to assist parties involved in packing containers to check the load has been appropriately loaded/secured, as well as to check their compliance with other container loading compliance requirements.



# Transport of shipping containers

Australia's heavy vehicle safety laws set out specific obligations for transport operators and heavy vehicle drivers, as well as consignees and consignors, about the handling and transport of freight containers.

In relation to the carriage of containers by road, the *Australian Load Restraint Guide 2018* recommends:

Shipping containers and flat-rack platforms are equipped with corner castings designed to interlock with mating twist locks for lifting or restraint.

Restrain shipping containers with four twist locks.

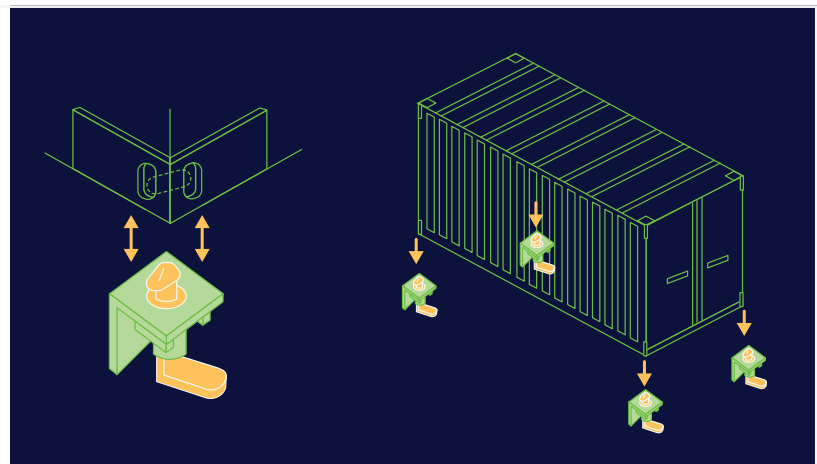

Load containers with doors to the rear of the carrying vehicle at all times.

If doors are towards the front of the carrying vehicle, the forward restraint may not be adequate for heavy loads.

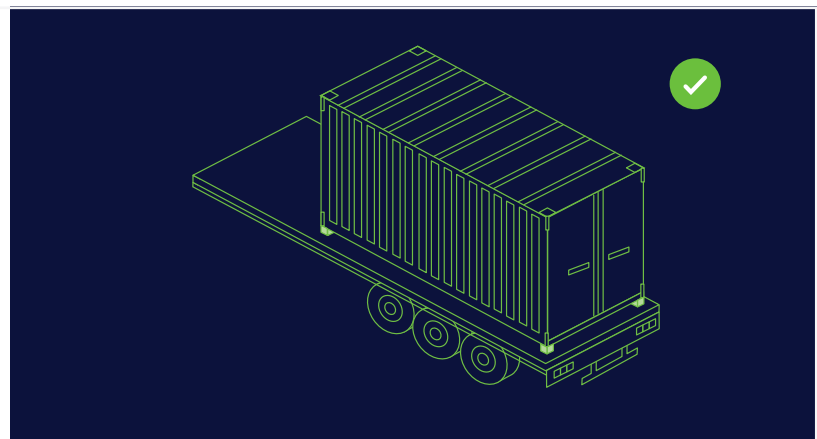

# Receipt and unpacking of containers

**The consignee or unpacker of a container should check that the unit is in good condition, and notify the shipping line and other parties in the container logistics chain of any significant damage. Where applicable, unpackers should check the integrity of the container seal and ensure the number matches the transport documentation.**

Unpackers should be alert to external signs that the consignment may present hazards, such as abnormally high temperatures, substances leaking from the unit or deformation of container panels. These may indicate that the container should be isolated, or other special care may be required before unpacking the cargo.

Be aware that the container may present a harmful atmosphere, either emanating from the cargo or remains of fumigants.

The consignee or unpacker should check the container and the cargo is free from visible pest contamination. Containers and their contents must also comply with Australian and New Zealand biosecurity requirements.

Before unpacking a container, conduct a risk assessment in relation to the planned unpacking activities, including any requirement to access the container or any part of it at a height above ground level. Ensure that suitable unpacking equipment and techniques are used.

Take additional precautions when opening the unit, in case cargo has shifted during transport. The use of a safety strap secured around the inner locking rods will minimise the free movement of the door when it is first opened.

Take account of the nature of the consignment (e.g. low friction plates or items with a high center of gravity) and be careful in removing lashing or blocking.

Any damage to the cargo detected during unpacking should be documented and communicated to the shipping line, shipper and / or transport operator, as appropriate (including any shift in stow or collapse of stow).

Unpackers are encouraged to take photographs of the container unpacking process, and particularly obtain photographic evidence of any damage encountered (to either the cargo or to the container). Where any damage, shifting or collapse is observed, engage with others in the supply chain, including the person who packed the container, to resolve any safety issues.

Several State Government Safe Work agencies have produced valuable safety guides for unpacking shipping containers. The guides provide information on how to manage health and safety risks when unpacking containers transported by land or sea. From the opening of the container doors, through to removing and transporting items to a storage location, the guides cover obligations under WH&S legislation.

The guides encourage a risk management approach – identifying all potential hazards associated with unpacking shipping containers, assessing them where necessary, and then eliminating the hazards so far as is reasonably practicable.

- [SafeWork NSW “Guide for Unpacking Shipping Containers” \(October 2016\)](#)
- [WorkSafe Victoria Guidance Note: Unpacking Shipping Containers \(June 2010\)](#)
- [SafeWork Australia “Managing Risks when Unpacking Shipping Containers \(February 2016\)](#)
- [NHVR - Regulatory Advice - Managing the risks of transporting freight in shipping containers](#)
- [WorkSafe Mahi Haumarua Aotearoa – Industry Guidance Containers – inspection and unpacking](#)

---

# Other safety and compliance activities

## Pests / contamination

**Confirm that the container and the cargo to be packed are both free from visible pest contamination. Take necessary steps to prevent contamination by pests.**

If timber is used for packing and bracing, ensure that it has been properly treated and marked in accordance with Australian biosecurity regulations. Failure to do so may result in the transport of pests that can devastate crops, plants, trees, and animals. The container and its cargo may also be denied entry into Australia and may be required to be returned to its origin.

Timber and bamboo packaging and dunnage (loose packaging) used to support, protect, or carry products for international trade are subject to Australian import conditions. The import conditions can be found in the Australian Biosecurity Import Conditions System (BICON) under 'timber and bamboo packaging' (for packaging imported as a commodity) or 'non-commodity' (for packaging used to support other commodities).

## Water damage / leakage

**Check for signs of rust or water trails that may indicate holes or other water ingress. If the condition of the container is not satisfactory or does not meet the requirements for the goods to be packed, contact your transport provider and container owner (shipping line).**

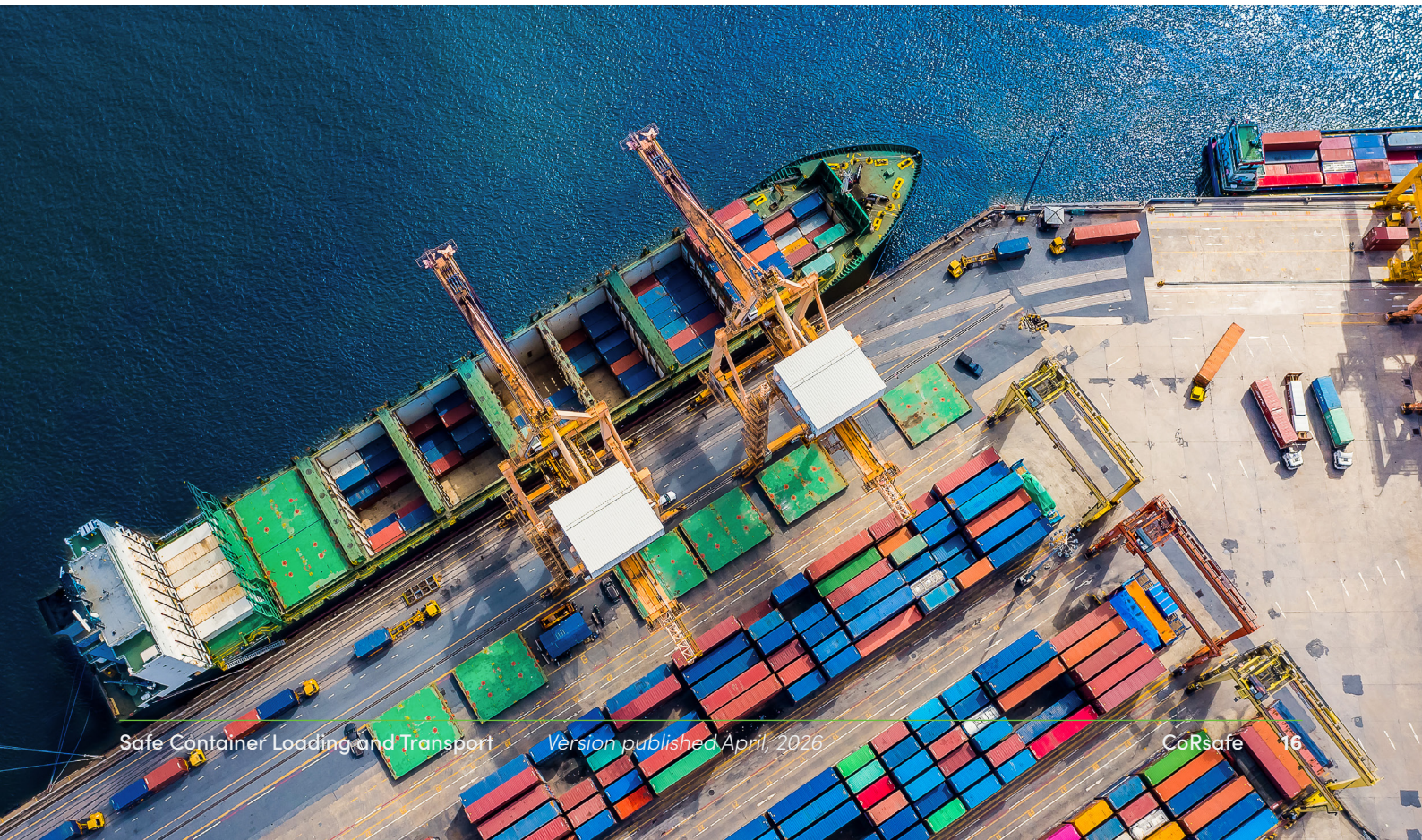

# Summary

**The transportation of cargo using containers enables viable supply chains, and is incredibly important to the ANZ economy.**

To ensure the safety of all parties involved in transporting containers, as well as to meet legislated obligations, it is important that appropriate systems, processes and procedures are created, implemented, followed and monitored.

Failure to manage the risks associated with transporting cargo by container could result in serious harm to people, property or the environment, and may incur significant fines/penalties under relevant legislation, such as CoR or WHS.

# Disclaimer

© 2026 NTI Limited (CoRsafe) ABN 84 000 746 109. General information only. CoRsafe bears no responsibility, and shall not be held liable, for any loss, damage or injury arising directly or indirectly from your use of or reliance on the information in this guideline.



## Appendix A -

# Container packing checklist

A checklist for the safe packing and avoidance of pest contamination of freight containers, produced by the Cargo Integrity Group<sup>1</sup>.

All questions have been designed to address criteria of the CTU Code<sup>2</sup>.

Instructions: Complete the checklist for each container to be packed. If ANY of the answers are "NO", stop packing, alert your supervisor. DO NOT dispatch the container.

1 - The packing area		YES	NO	N/A
1	Is the type of container appropriate for the cargo to be carried?	<input type="checkbox"/>	<input type="checkbox"/>	<input type="checkbox"/>
2	Is the container positioned so that it can be accessed safely?	<input type="checkbox"/>	<input type="checkbox"/>	<input type="checkbox"/>
3	Have steps been taken to avoid contamination of the packing area by pests?	<input type="checkbox"/>	<input type="checkbox"/>	<input type="checkbox"/>
4	Has a packing plan been prepared showing the arrangements of goods in the container?	<input type="checkbox"/>	<input type="checkbox"/>	<input type="checkbox"/>
5	Are the maximum permitted payload limits of the container sufficient for the intended load?	<input type="checkbox"/>	<input type="checkbox"/>	<input type="checkbox"/>
6	Do all timber pallets, dunnage or other wood packing material meet ISPM-15 standards and show the required markings?	<input type="checkbox"/>	<input type="checkbox"/>	<input type="checkbox"/>
7	Have staff assigned to pack the container been trained to understand the practices of safe packing and securing and avoidance of pest contamination?	<input type="checkbox"/>	<input type="checkbox"/>	<input type="checkbox"/>
2 - Container condition		YES	NO	N/A
1	Is the container exterior free from soil or other visible infestation by pests?	<input type="checkbox"/>	<input type="checkbox"/>	<input type="checkbox"/>
2	Is the container exterior in good condition, and not significantly distorted, cracked or bent?	<input type="checkbox"/>	<input type="checkbox"/>	<input type="checkbox"/>
3	Does the container have a valid CSC Approval Plate?	<input type="checkbox"/>	<input type="checkbox"/>	<input type="checkbox"/>
4	Is the container interior free from signs of damage, signs of water ingress, rust, residues, stains or debris?	<input type="checkbox"/>	<input type="checkbox"/>	<input type="checkbox"/>
5	Is the container interior free from soil or other visible infestation by pests?	<input type="checkbox"/>	<input type="checkbox"/>	<input type="checkbox"/>
3 - Packing the container		YES	NO	N/A
1	Is the cargo to be packed free from soil or other visible infestation by pests?	<input type="checkbox"/>	<input type="checkbox"/>	<input type="checkbox"/>
2	Has heavier cargo been packed at the bottom of the container, with any lighter cargo on top?	<input type="checkbox"/>	<input type="checkbox"/>	<input type="checkbox"/>
3	Is the cargo distributed evenly across the floor of the container to spread the load?	<input type="checkbox"/>	<input type="checkbox"/>	<input type="checkbox"/>
4	Is the centre of gravity approximately in the centre of the container?	<input type="checkbox"/>	<input type="checkbox"/>	<input type="checkbox"/>
5	Has the cargo been packed in approximately even layers?	<input type="checkbox"/>	<input type="checkbox"/>	<input type="checkbox"/>
6	Have packages with package orientation labels been stowed the correct way up?	<input type="checkbox"/>	<input type="checkbox"/>	<input type="checkbox"/>
7	Has locking, blocking or lashing been used to prevent the cargo from sliding and tipping in the container in any direction?	<input type="checkbox"/>	<input type="checkbox"/>	<input type="checkbox"/>

<b>4 - Dangerous Goods</b>		<b>YES</b>	<b>NO</b>	<b>N/A</b>
1	Are all Dangerous Goods packages marked and labelled in accordance with the IMDG Code?	<input type="checkbox"/>	<input type="checkbox"/>	<input type="checkbox"/>
2	Are all Dangerous Goods packages undamaged and in sound condition?	<input type="checkbox"/>	<input type="checkbox"/>	<input type="checkbox"/>
3	Where Dangerous Goods comprise only part of the cargo, are they packed as close to the doors as possible?	<input type="checkbox"/>	<input type="checkbox"/>	<input type="checkbox"/>
4	Has the container been placarded in accordance with the IMDG Code?	<input type="checkbox"/>	<input type="checkbox"/>	<input type="checkbox"/>

<b>5 – After packing the container, but before closing the doors</b>		<b>YES</b>	<b>NO</b>	<b>N/A</b>
1	Have all void spaces (gaps) within the cargo stow and / or between the cargo and container structure been filled?	<input type="checkbox"/>	<input type="checkbox"/>	<input type="checkbox"/>
2	Is the cargo blocking and bracing distributed over a sufficiently large area of the container (e.g. by use of spreader beams)?	<input type="checkbox"/>	<input type="checkbox"/>	<input type="checkbox"/>
3	Are lashings secured to the container so as not to over-stress its structure?	<input type="checkbox"/>	<input type="checkbox"/>	<input type="checkbox"/>
4	Are both the interior and the exterior of the container, and its cargo, free of soil, or other visible infestation by pests?	<input type="checkbox"/>	<input type="checkbox"/>	<input type="checkbox"/>

<b>Closing the container</b>		<b>YES</b>	<b>NO</b>	<b>N/A</b>
	Have the doors of the container been securely closed and latched?	<input type="checkbox"/>	<input type="checkbox"/>	<input type="checkbox"/>
	Has a seal been affixed to the container and its number recorded?	<input type="checkbox"/>	<input type="checkbox"/>	<input type="checkbox"/>

<b>Dispatching the container</b>		<b>YES</b>	<b>NO</b>	<b>N/A</b>
	For the packed container, has the Verified Gross Mass been communicated to the carrier as early as required by the carrier?	<input type="checkbox"/>	<input type="checkbox"/>	<input type="checkbox"/>
	For the packed container, has the identity of the container and the seal number been communicated to the carrier as early as required by the carrier?	<input type="checkbox"/>	<input type="checkbox"/>	<input type="checkbox"/>
	For the cargo, has an accurate description (including classification) of the cargo itself and the packaging been communicated to the carrier, as early as required by the carrier?	<input type="checkbox"/>	<input type="checkbox"/>	<input type="checkbox"/>
	For the cargo, have the number and types of packages and the cargo mass (for Customs purposes) been communicated to the carrier, as early as required by the carrier?	<input type="checkbox"/>	<input type="checkbox"/>	<input type="checkbox"/>
	For Dangerous Goods, has a Shipper's Declaration and, where required, a Packing Certificate declaration been made and communicated to the carrier as early as required by the carrier?	<input type="checkbox"/>	<input type="checkbox"/>	<input type="checkbox"/>

---

1 Copyright © 2022 Jointly held by the partners of the Cargo Integrity Group, comprising Bureau International des Containers et du Transport Intermodal (BIC), Container Owners Association (COA), International Federation of Freight Forwarders Associations (FIATA), Global Shippers Forum (GSF), International Cargo Handling Co-ordination Association (ICHCA International), TT Club and World Shipping Council (WSC).. All rights reserved. All use, in any form or by any means, should appropriately attribute the copyright holders. LSS does not claim ownership (including copyright ownership) over the Checklist included in this Appendix A.

2 The CTU Code is the IMO / ILO / UNECE Code of Practice for Packing of Cargo Transport Units, 2014 edition. CTU Code can be found on both the websites of the International Maritime Organization (IMO) <https://www.imo.org/en/OurWork/Safety/Pages/CTU-Code.aspx> and the United Nations Economic Commission for Europe (UNECE) <https://unece.org/transport/intermodal-transport/imoilounece-code-practice-packing-cargo-transport-units-ctu-code>

Copyright © 2022 Jointly held by the partners of the Cargo Integrity Group, comprising Bureau International des Containers et du Transport Intermodal (BIC), Container Owners Association (COA), International Federation of Freight Forwarders Associations (FIATA), Global Shippers Forum (GSF), International Cargo Handling Co-ordination Association (ICHCA International), TT Club and World Shipping Council (WSC).. All rights reserved. All use, in any form or by any means, should appropriately attribute the copyright holders.

© 2026 NTI Limited (CoRsafe) ABN 84 000 746 109. General information only. CoRsafe bears no responsibility, and shall not be held liable, for any loss, damage or injury arising directly or indirectly from your use of or reliance on the information in this guideline.

Diagrams used in this guide have been taken from the 2018 Australian Load Restraint Guide owned by the National Transport Commission ('NTC') and is being licensed by LSS under a creative commons license for use in this Container Guide(<https://creativecommons.org/licenses/by/4.0/legalcode#s6a> - Attribution 4.0 International). Your use of this Container Guide guide implies your acceptance of the terms and conditions of the creative commons license ("CC License T&Cs"). Section 5 of the CC License T&Cs refers to Warranties and Limitation of Liability, please consider this before viewing and using the guide. The diagrams in this Container Guide have been modified for style and formatting, however concepts illustrated remain the same. The version of the Australian Load Restraint Guide used to prepare this Container Guide was the version available on the NTC website in April 2024. LSS is not responsible for your use or reliance on the information provided in this Container Guide.

**CoRsafe** *in partnership with*



**Container Transport  
Alliance Australia**

*Dedicated. Connected. Better.*

☎ **+61 7 3292 9876**

✉ **support@cor-safe.com.au**

📍 **cor-safe.com.au/**

